

N Ø R  
F A X

Brukervennlig og bærekraftige  
løsninger til nordiske uterom

Dokumentet er laget i samarbeid med  
produsent

[post@norfax.no](mailto:post@norfax.no)

66 80 00 60

[norfax.no](http://norfax.no)

# Montasjeanvisning for Bike-Up Pro Twin Tower Lang skinne med gassdemper - tosidig

**2+2+2+2**  
**3+3+3+3**  
**4+4+4+4**



# Teknisk beskrivelse Bike-Up Pro Twin Tower Lang skinne med gassdemper - tosidig

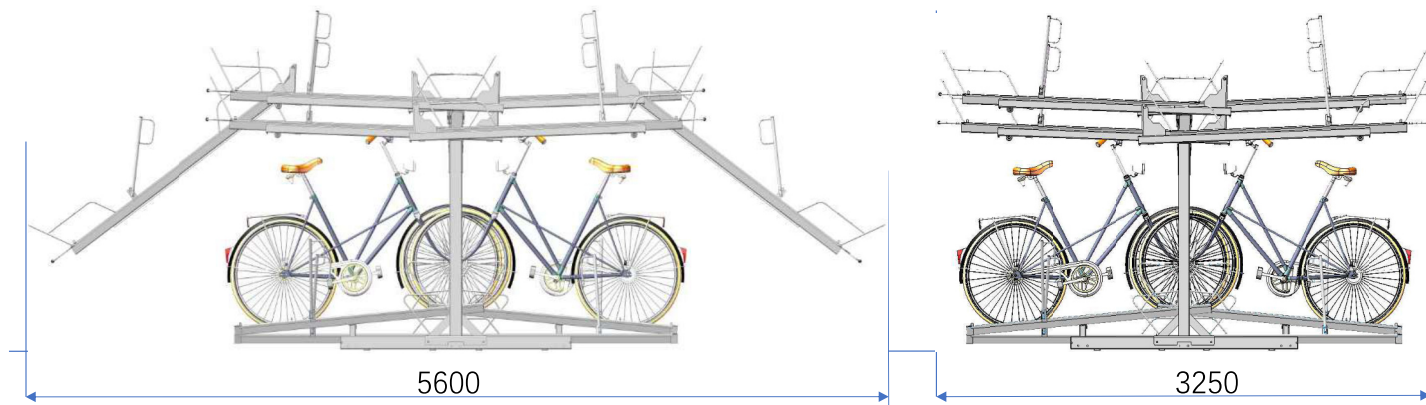

Øverste posisjon  
Min. takhøyde 2620mm

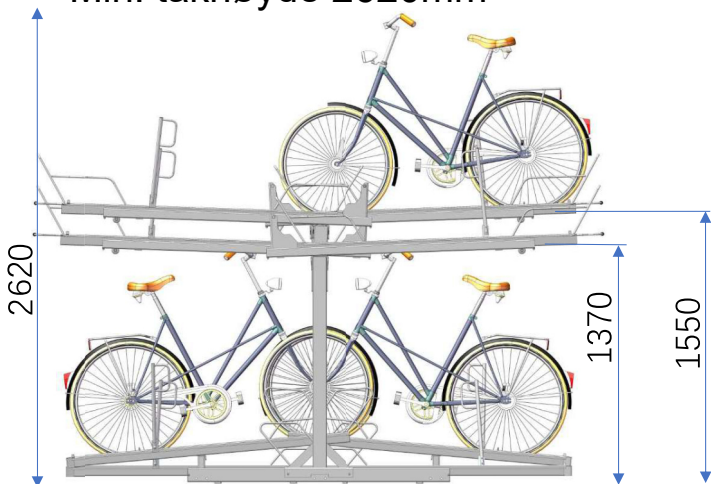

Midtre posisjon  
Min. takhøyde 2520mm



Laveste posisjon  
Min. takhøyde 2420mm

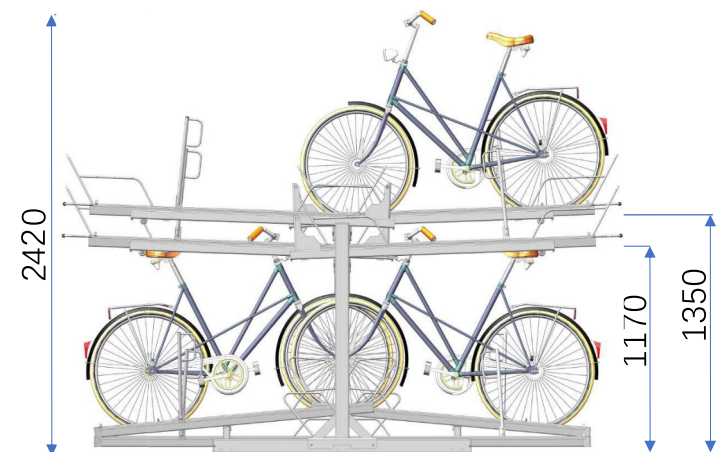

# Teknisk beskrivelse Bike-Up Pro Twin Tower Lang skinne med gassdemper - tosidig

- Min. avstand fra frontvegg = 0 mm
- Min. avstand fra høyre eller venstre vegg = 100 mm
- Min. takhøyde er 2420 mm
- Rommets bredde er min. 3600 mm
- Bredden på rommet med sykkelstativ på to motsatte vegger er min. 5600 mm
- Minste avstand mellom to sykkelstativ er 0 mm  
(hvis syklene er i forskjellige høyder, ellers 200 mm mellom)

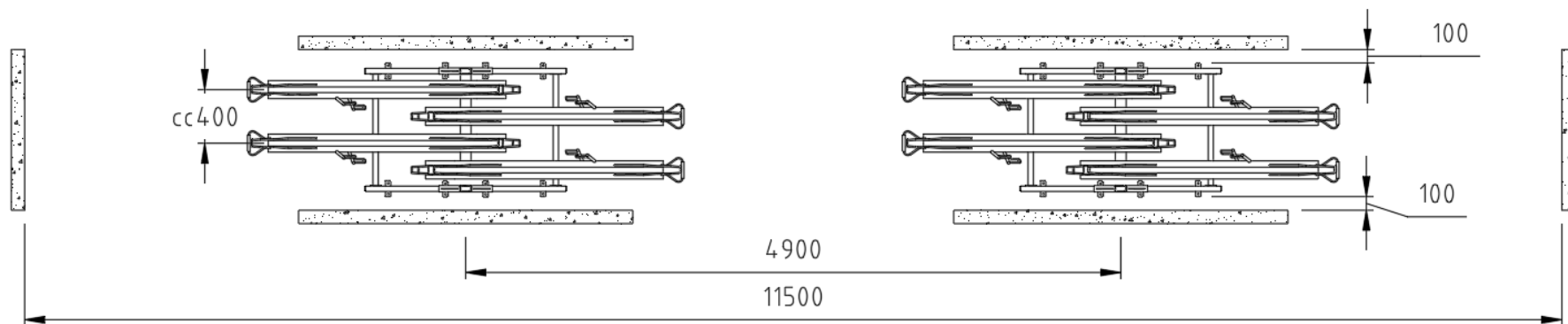
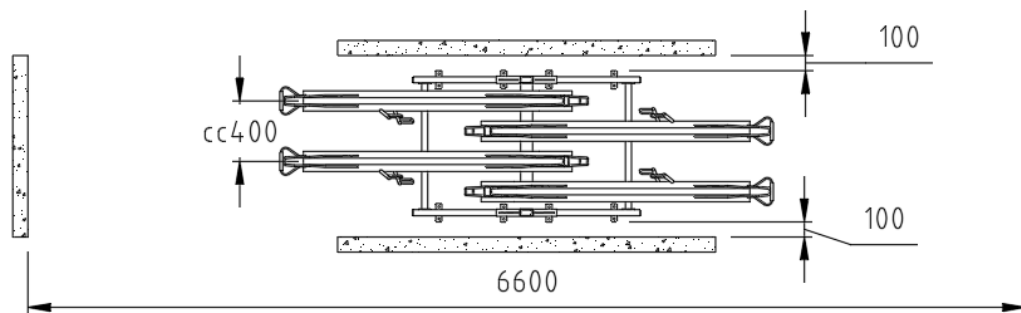

# Teknisk beskrivelse Bike-Up Pro Twin Tower

## Lang skinne med gassdemper - tosidig

### Følgende verktøy trengs

1. Metallborr Ø10 mm
2. Betongborr Ø8 mm
3. Pipesett med skralle 16 og 17 mm
4. Ringnøkkel 16 og 17 mm
5. Elektrisk drill
6. Slagborr for boring gulv/betong

Montering av Bike-Up Pro Twin Tower 2+2+2+2 side 4-5

Montering av Bike-Up Pro Twin Tower 3+3+3+3 side 6-7

Montering av Bike-Up Pro Twin Tower 4+4+4+4 side 8-9

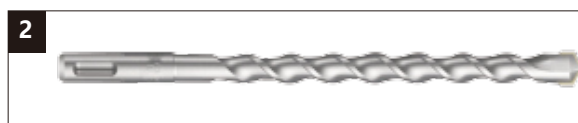

# Montering av stativ 100-2222 (2+2+2+2)

## Steg 1, Monter nedre bakre balk

Deler

1x "20145 - base" (171159)  
1x "20145 - søyle" (171158)  
2x Skrue M10 x 70 mm  
2x M10 mutter

- 1:1 Sett inn skruer som vist.  
1:2 Skru fast mutter løst for hånd.



1:1

1:2

1:3



## Steg 2, Monter nedre midtbjelke

Deler

Deler fra steg 1  
1x "20153-Twin" (171167)  
4x Skrue M10 x 70 mm  
4x M10 mutter

- 2:1 Sett inn skruer som vist.  
2:2 Skru mutter løst for hånd.

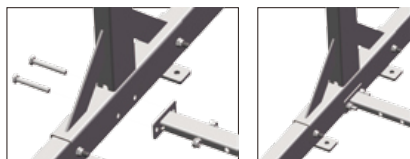

2:1

2:2



## Steg 3, Monter nedre endebjelke

Deler

Deler fra steg 2  
2x "20154-Twin" (171168)  
8x Skrue M10 x 70 mm  
8x M10 mutter

- 3:1 Sett sammen deler  
3:2 Skru mutter løst for hånd

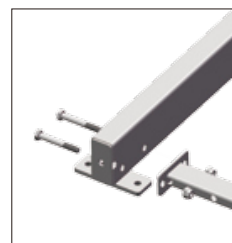

3:1

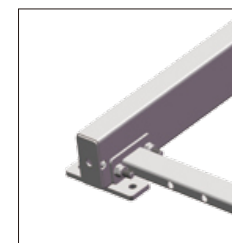

3:2



## Steg 4, Monter øvre bjelke

Deler

Deler fra steg 3  
1x "20152-Twin" (171166)  
4x Skrue M10 x 110 mm  
4x M10 mutter

- 4:1-4:2 Sett sammen deler  
4:3 Skru mutter løst for hånd

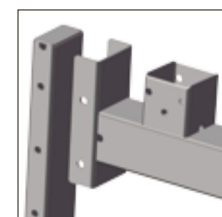

4:1

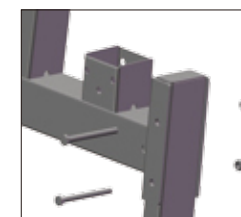

4:2

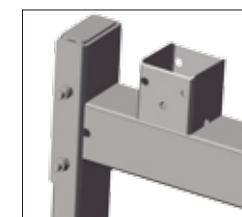

4:3



### Steg 5, Monter skinnene på underetasjen

Deler

Deler fra steg 4  
4x «20011» (fast skinne)  
16x Skruer M10 x 70 mm  
16x M10 mutter

5:1 Sett sammen deler

5:2 Skru mutter løst for hånd

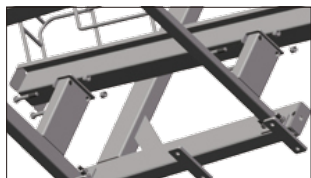

5:1



5:2

### Steg 6, Vend sykkelstativet og skru til muttere

6:1 Vend sykkelstativet.

6:2 Skru fast alle muttere

6:3 Deretter, vend sykkelstativet tilbake.

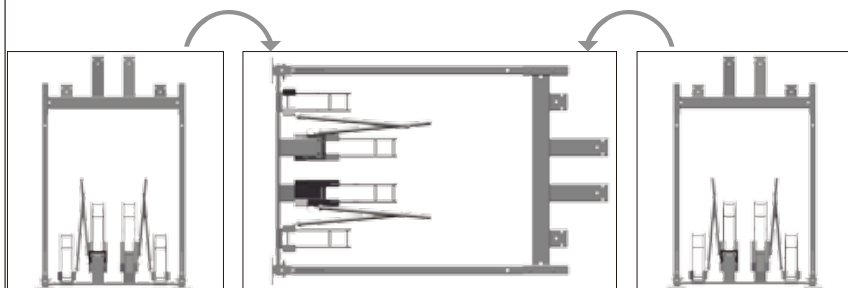

6:1

6:2

6:3

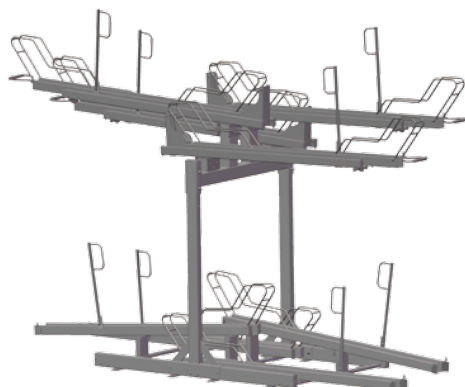

### Steg 7, Skru fast sykkelstativet i gulvet

Deler

Komplett sykkelstativ  
Minst 8x skruer tilpasset underlaget  
Skru fast i gulvet

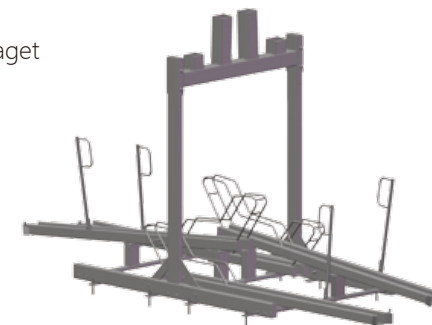
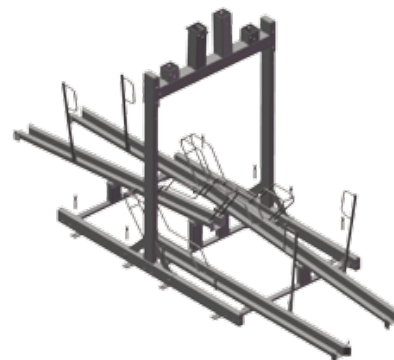

### Steg 8, Monter skinner på overetasjen

Deler

Deler fra steg 7  
4x «20005» (utdragbar skinne)  
12x Skruer M10 x 110 mm  
12x M10 mutter

8:1-8:2 Sett sammen delene

8:3 Skru til muttere

8:4 Skru fast alle muttere, skru den nedre skruen først, så de to øvre, avslutt med å skru til nedre en gang til.

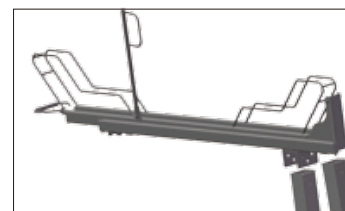

8:1

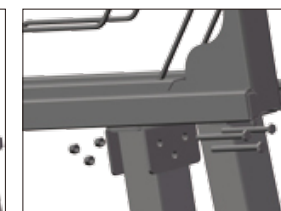

8:2

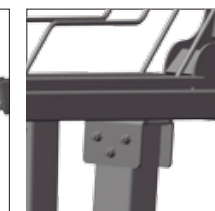

8:3

# Montering av stativ 100-3333 (3+3+3+3)

## Steg 1, Monter nedre bakre balk

Deler

1x "20145 - base" (171159)  
1x "20145 - søyle" (171158)  
2x Skrue M10 x 70 mm  
2x M10 mutter

- 1:1 Sett inn skruer som vist.  
1:2 Skru fast mutter løst for hånd.

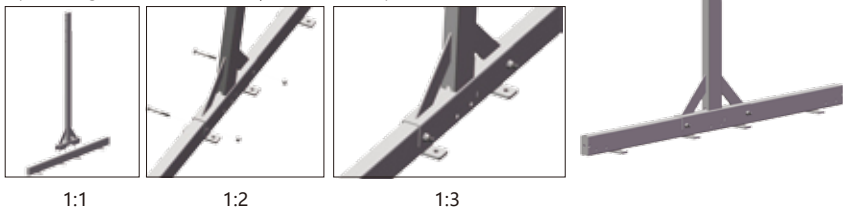

## Steg 2, Monter nedre midtbjelke

Deler

Deler fra steg 1  
1x "20150-Twin" (171164)  
4x Skrue M10 x 70 mm  
4x M10 mutter

- 2:1 Sett inn skruer som vist.  
2:2 Skru mutter løst for hånd.

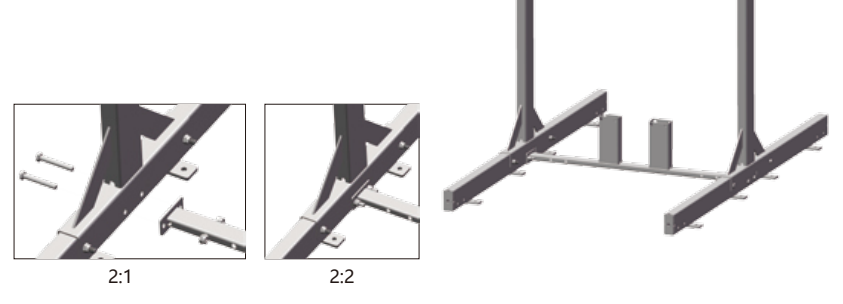

## Steg 3, Monter nedre endebjelke

Deler

Deler fra steg 2  
2x "20151-Twin" (171165)  
8x Skrue M10 x 70 mm  
8x M10 mutter

- 3:1 Sett sammen deler  
3:2 Skru mutter løst for hånd



## Steg 4, Monter øvre bjelke

Deler

Deler fra steg 3  
1x "20149-Twin" (171163)  
4x Skrue M10 x 110 mm  
4x M10 mutter

- 4:1-4:2 Sett sammen deler  
4:3 Skru mutter løst for hånd

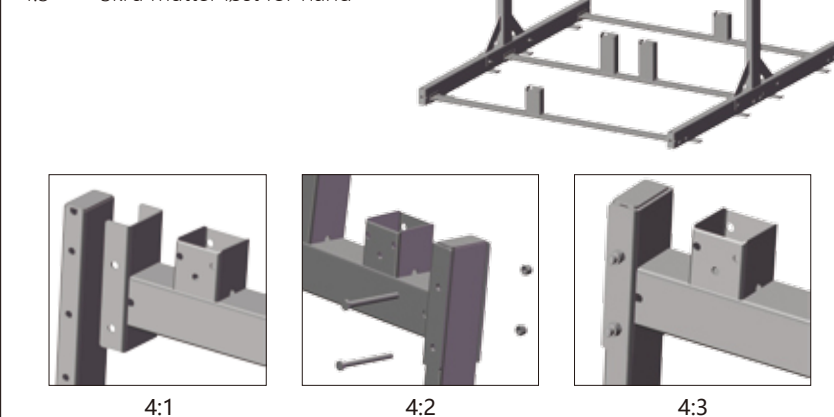

### Steg 5, Monter skinnene på underetasjen

Deler

Deler fra steg 4  
6x «20011» (fast skinne)  
24x Skruer M10 x 70 mm  
24x M10 mutter

- 5:1 Sett sammen deler
- 5:2 Skru mutter løst for hånd

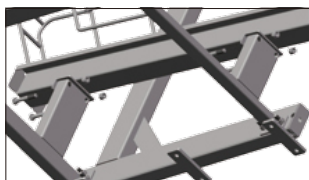
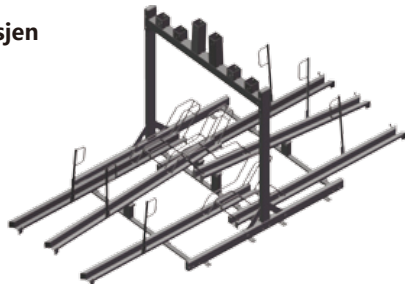

5:1



5:2

### Steg 6, Vend sykkelstativet og skru til muttere

- 6:1 Vend sykkelstativet.
- 6:2 Skru fast alle muttere
- 6:3 Deretter, vend sykkelstativet tilbake.

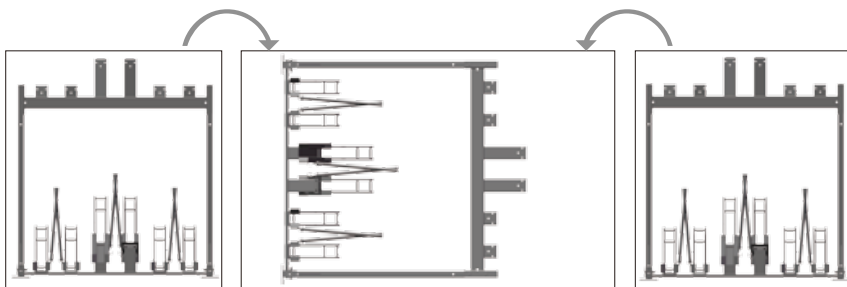

6:1

6:2

6:3

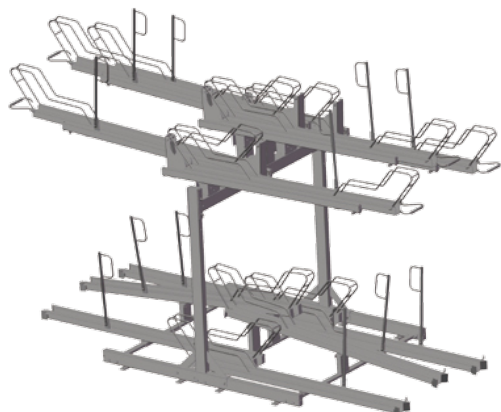

### Steg 7, Skru fast sykkelstativet i gulvet

Deler

Komplett sykkelstativ  
Minst 8x skrue tilpasset underlaget  
Skrus fast i gulvet

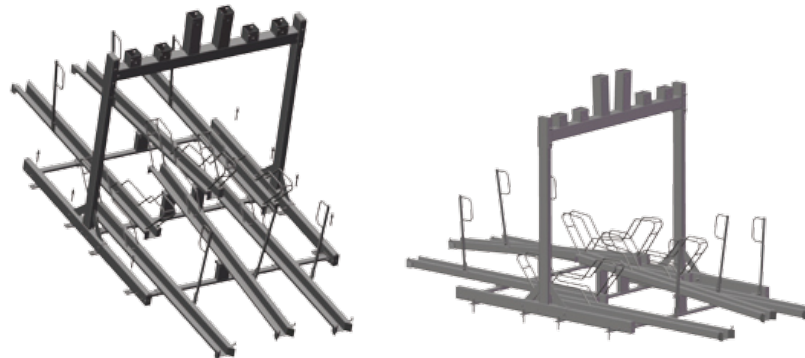

### Steg 8, Monter skinner på overetasjen

Deler

Deler fra steg 7  
6x «20005» (utdragbar skinne)  
18x Skruer M10 x 110 mm  
18x M10 mutter

- 8:1-8:2 Sett sammen delene
- 8:3 Skru til muttere
- 8:4 Skru fast alle muttere, skru den nedre skruen først, så de to øvre, avslutt med å skru til nedre en gang til.

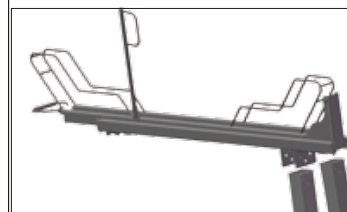

8:1

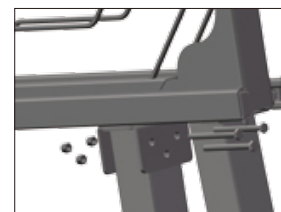

8:2

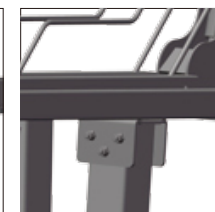

8:3

# Montering av stativ 100-4444 (4+4+4+4)

## Steg 1, Monter nedre bakre balk

Deler

- 1x "20145 - base" (171159)
- 1x "20145 - søyle" (171158)
- 2x Skruer M10 x 70 mm
- 2x M10 mutter

- 1:1 Sett inn skruer som vist.
- 1:2 Skru fast mutter løst for hånd.



1:1

1:2

1:3



## Steg 3, Monter nedre endebjelke

Deler

- Deler fra steg 2
- 2x "20148-Twin" (171162)
- 8x Skruer M10 x 70 mm
- 8x M10 mutter

- 3:1 Sett sammen deler
- 3:2 Skru mutter løst for hånd



3:1



3:2



## Steg 4, Monter øvre bjelke

Deler

- Deler fra steg 3
- 1x "20146-Twin" (171160)
- 4x Skruer M10 x 110 mm
- 4x M10 mutter

- 4:1-4:2 Sett sammen deler
- 4:3 Skru mutter løst for hånd

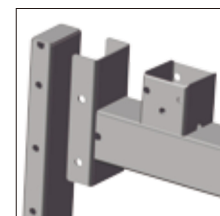

4:1

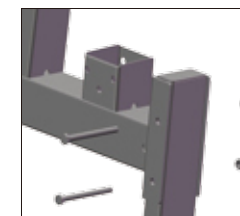

4:2

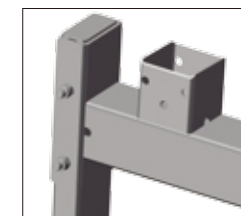

4:3



## Steg 2, Monter nedre midtbjelke

Deler

- Deler fra steg 1
- 1x "20147-Twin" (171161)
- 4x Skruer M10 x 70 mm
- 4x M10 mutter

- 2:1 Sett inn skruer som vist.
- 2:2 Skru mutter løst for hånd.

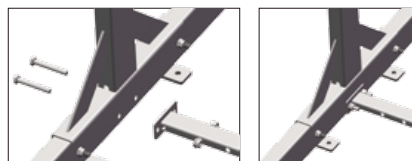

2:1

2:2



### Steg 5, Monter skinnene på underetasjen

Deler

Deler fra steg 4  
8x «20011» (fast skinne)  
32x Skruer M10 x 70 mm  
32x M10 mutter

- 5:1 Sett sammen deler
- 5:2 Skru mutter løst for hånd

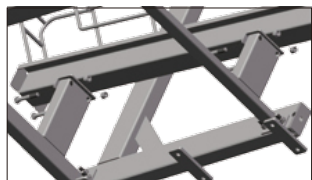
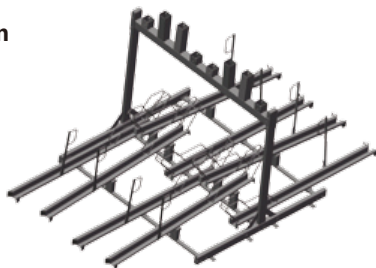

5:1



5:2

### Steg 6, Vend sykkelstativet og skru til muttere

- 6:1 Vend sykkelstativet.
- 6:2 Skru fast alle muttere
- 6:3 Deretter, vend sykkelstativet tilbake.

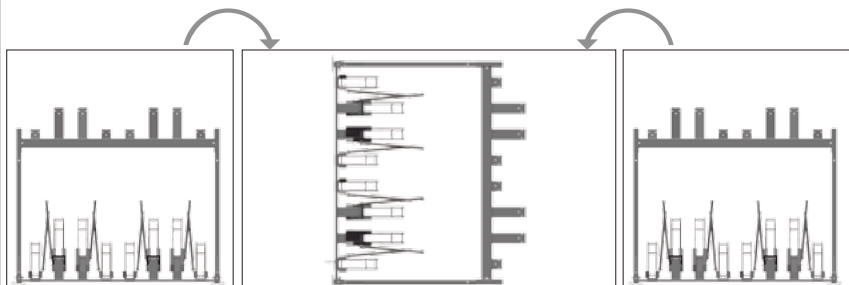

6:1

6:2

6:3

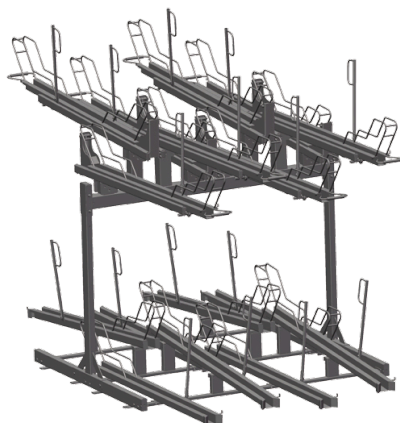

### Steg 7, Skru fast sykkelstativet i gulvet

Deler

Komplett sykkelstativ  
Minst 8x skruer tilpasset underlaget  
Skru fast i gulvet



### Steg 8, Monter skinner på overetasjen

Deler

Deler fra steg 7  
4x «20005» (utdragbar skinne)  
24x Skruer M10 x 110 mm  
24x M10 mutter

- 8:1-8:2 Sett sammen delene
- 8:3 Skru til muttere
- 8:4 Skru fast alle muttere, skru den nedre skruen først, så de to øvre, avslutt med å skru til nedre en gang til.

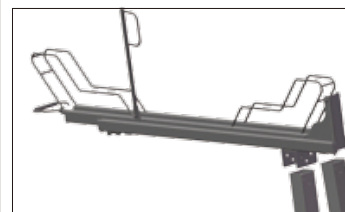

8:1

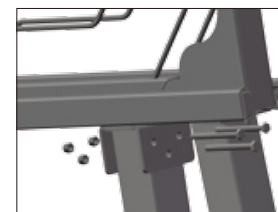

8:2

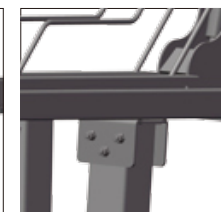

8:3